

Analog Input to Triac (AC) Pulse Output

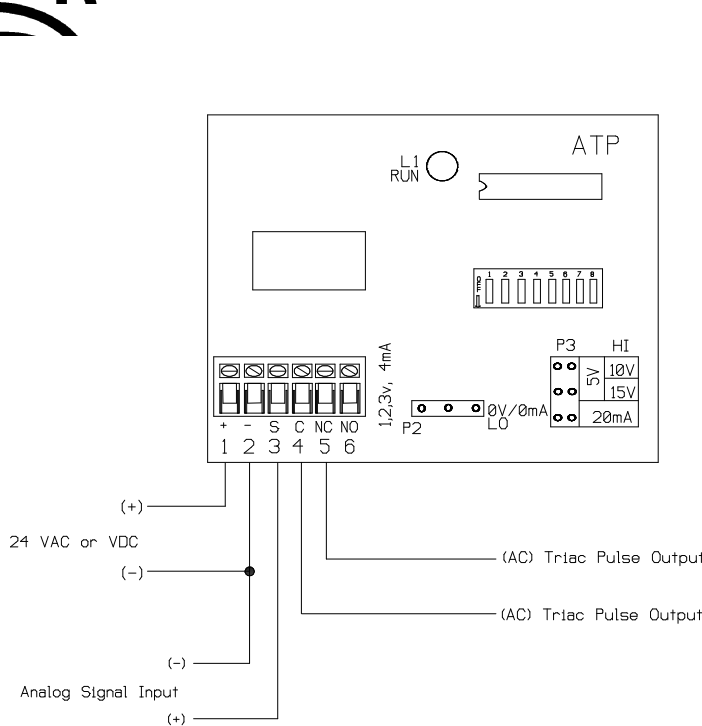

Jumper P2 & P3 Shunt Positions

Analog Input	P2 LO (Offset)	P3 HI (Maximum)
0-5V		
0-10V		
0-15V		
0-20mA		
1-5V		
2-10V		
3-15V		
4-20mA		

INSTALLATION

READ THESE INSTRUCTIONS BEFORE YOU BEGIN INSTALLATION

Ground yourself to discharge static electricity before touching any electronic equipment, as some components are static sensitive. The interface device can be mounted in any position. If circuit board slides out of snap track, a non-conductive "stop" may be required. Use only fingers to remove board from snap track. Slide out of snap track or push up against side of snap track and lift that side of the circuit board to remove. Do not flex board. Use no tools.

POWER CONNECTIONS

Be sure to follow all local and electrical codes. Refer to wiring diagram for connection information.

- 1) It is highly suggested that the 24 VAC neutral of all transformers be earthed at the transformer. Analog input, digital input, and analog output circuits should not be earth grounded at two points. Any field device connected to this transformer must use the same common. If you are not sure of other field device configuration, use separate transformers.
- 2) If the AC or DC power is shared with other devices that have coils such as relays, solenoids, or other inductors, each coil must have an MOV (if AC), a diode (if DC), AC or DC Transorb, or other spike snubbing device across each of the shared coils. Without these snubbers, coils produce very large voltage spikes when de-energizing that can cause malfunction or destruction of electronic circuits.

ATP PULSE TIMING

The ATP converts an analog signal into a digital pulse output signal (triac AC only). The analog input signal range is selected by the jumper shunts P2 and P3 (see diagram above).

Pulse timing consists of an "ON" pulse and an "OFF" interval. "OFF" interval is 1 second on standard and custom ranges.

The standard ranges for Version 1 or 2, are selected by dip switch 1 "ON" and proper settings of switches 2 and 3, allows for four different output timing ranges. Switches 4 through 8 are not active when switch 1 is on. Version 2 operates the same as Version 1 except when the input falls at or below 10% of the input signal range, no pulse output occurs, allowing for "OFF" setting of electric heat Solid State Relays (SSR's).

Input Signal									Standard Output Range			
0-5 V	1-5 V	0-10 V	2-10 V	0-15 V	3-15 V	0-20 mA	4-20 mA	STEPS	DIP: 1, 3 20ms/step ON	1 23ms/step ON	1, 2 100ms/step ON	1, 2, 3 9ms/step ON
0	1	0	2	0	3	0	4	0	0	0	0.1	0.59
1.25	2	2.5	4	3.75	6	5	8	64	1.3	1.5	6.5	1.18
2.5	3	5	6	7.5	9	10	12	128	2.5	3	12.8	1.76
3.75	4	7.5	8	11.25	12	15	16	191	3.8	4.5	19.2	2.35
5	5	10	10	15	15	20	20	255	5	6	35.5	2.93
No pulse is output when Version 2 input falls at or below 10% of the input signal range.									J O H N S O N	S O L I D Y N E	A N D O V E R	N O V A R

The custom mode (refer to chart below) allows for a variety of pulse timing ranges. The custom mode, selected by dip switch 1 "OFF", allows switches 2 through 8 to select "ON" pulse timing ranges. These "ON" times are cumulative and multiple switches can be selected.

Example: 0-10V signal input to an output pulse range of 150ms to 38.4 seconds.

1. To obtain a starting pulse width signal of 150 milliseconds(ms) turn switches 2 & 3 ON, all others OFF (dip switch 2 on = 50ms at 0 volts, and dip switch 3 on = 100ms at 0 volts).
2. By looking at the bottom chart note that at 10 volts input signal, the values for switches 2 & 3 "ON" are 12.8 and 25.6 seconds respectively, totalling 38.4 seconds.

The output range selected is now 150ms to 38.4 seconds.

All times on the charts are shown in seconds (or portion of) with a maximum 6.4 seconds. A pulsing "RUN" LED indicates pulse width signal output.

Input Signal									Custom Output Range (DIP Switch Values if ON)							
0-5 V	1-5 V	0-10 V	2-10 V	0-15 V	3-15 V	0-20 mA	4-20 mA	STEPS	2 50ms/step ON	3 100ms/step ON	4 200ms/step ON	5 400ms/step ON	6 800ms/step ON	7 1.6s/step ON	8 3.2s/step ON	2-8 6.35s/step ON
0	1	0	2	0	3	0	4	0	0.05	0.1	0.2	0.4	0.8	1.6	3.2	6.4
1.25	2	2.5	4	3.75	6	5	8	64	3.3	6.5	13	26	52	104	208	413
2.5	3	5	6	7.5	9	10	12	128	6.5	12.9	25.8	52	103	206	413	819
3.75	4	7.5	8	11.25	12	15	16	191	9.6	19.2	38.4	77	154	307	614	1219
5	5	10	10	15	15	20	20	255	12.8	25.6	51.2	102	205	410	819	1626

No pulse is output when Version 2 input falls at or below 10% of the input signal range.

Power Supply:	Voltage: 24 VAC or 24 VDC, +/- 10%	Digital Output:	Triac
	Current: 50 mA		Voltage: 22-28 VAC only
Analog Input:			Current: 3 amps
	Voltage/Impedance: 0-15VDC/1,000,000 ohms		
	Current/Impedance: 0-20 mA/250 ohms		