



DMUX-4

Novar™ Pulse Width Modulated Input to Four Addressable Relay Outputs Program # 0130YOB

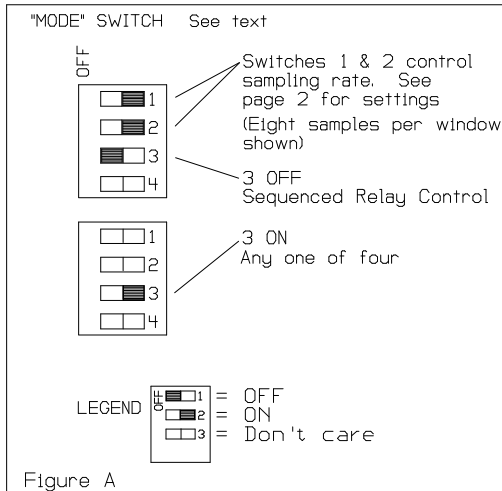
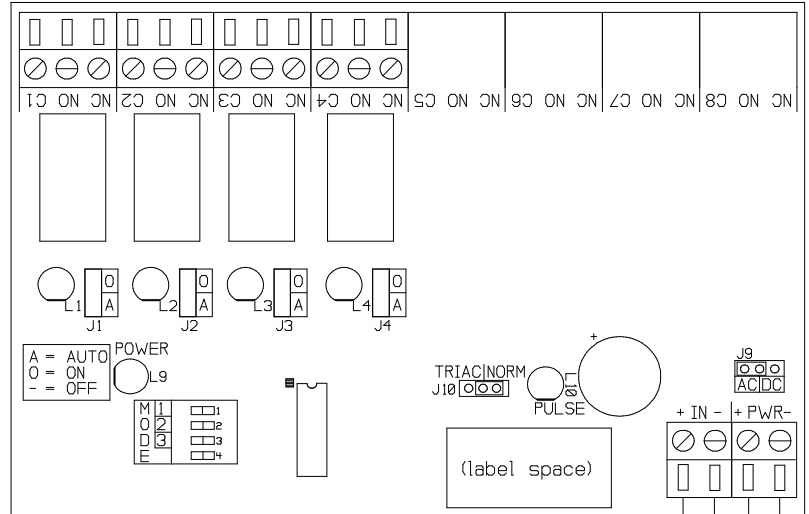

Figure A



Connections (see Fig F, G, H, or I)

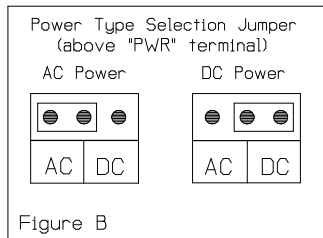

Figure B

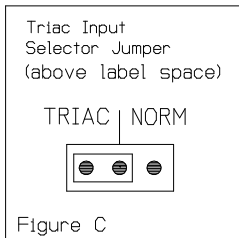

Figure C

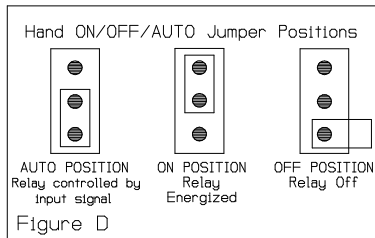
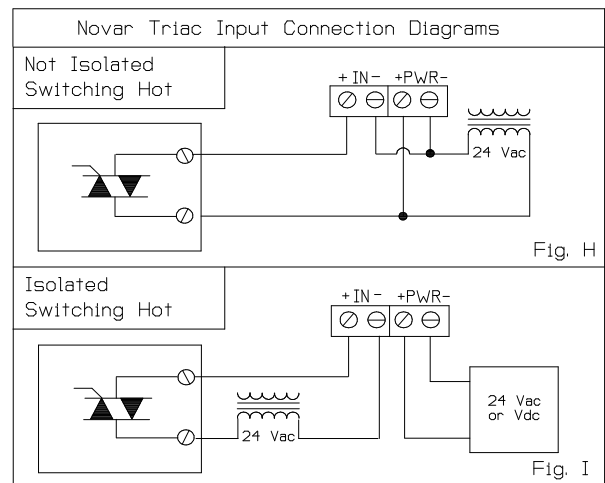
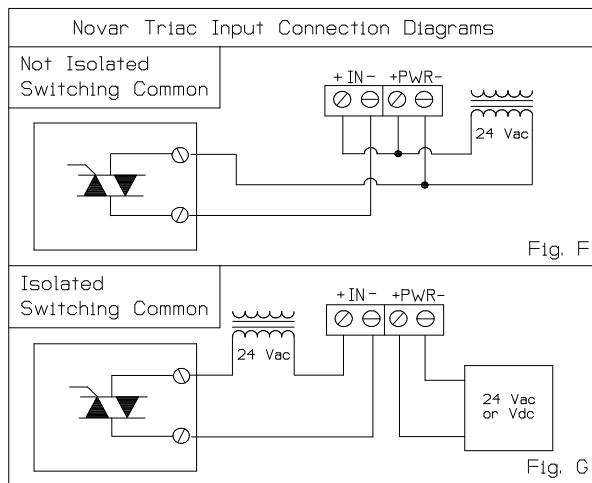

Figure D



Signal connections to DMUX: Switch either the hot (+) or common (-).



GENERAL

This DMUX converts a Novar™ 0.59-2.93 second pulse width modulated signal (5-24 VAC triac) into one of four relay outputs, or sequential (additive) one through four relay outputs.

READ THESE INSTRUCTIONS BEFORE YOU BEGIN INSTALLATION.

ALL JUMPER AND DIP SWITCH SETTINGS SHOULD BE MADE BEFORE APPLYING POWER.

Ground yourself before touching board. Some components are static sensitive.

MOUNTING:

Circuit board may be mounted in any position. If circuit board slides out of snap track, a non-conductive "stop" may be required. Use only fingers to remove board from snap track. Slide out of snap track or push against side of snap track and lift that side of the circuit board to remove. Do not flex board. Use no tools.

SAMPLING RATE

Four sampling rates for system response time (1, 2, 4, and 8 samples per timing window) are selectable by the mode DIP switches 1 and 2. The sample rates require the chosen number of pulses to fall consecutively within the same window before allowing an update of the output of the DMUX. Settings are as follows:

<u>SAMPLING RATE</u>	<u>DIP Switch 1</u>	<u>DIP Switch 2</u>
1 Sample	OFF	OFF
2 Samples	ON	OFF
4 Samples	OFF	ON
8 Samples	ON	ON

UPDATE OF RELAYS

The relays shall update upon cessation of the last pulse. If the user chooses 4 samples per timing window, the relays shall update at the cessation of the 4th sample. If relays flutter on and off, increase the sample rate.

SETTING CONTROL MODES

ONE OF FOUR RELAYS

DIP Switch 3 "ON" (DIP Switch 4 N/A). Input signal selects 1 of 4 Relays. All other relays off. A single pulse width modulated signal allows only one relay at a time to be on. This mode is useful as an analog or digital signal multiplexer.

<u>PULSE LENGTH IN SECONDS</u>		<u>RELAY ACTION</u>
<u>Less than or equal to</u>	<u>Less than</u>	
.001	to .40	= NONE
.40	to .83	= ALL OFF
1.10	to 1.36	= 1 ON, Others OFF
1.63	to 1.89	= 2 ON, Others OFF
2.16	to 2.42	= 3 ON, Others OFF
2.69	to 10.00	= 4 ON, Others OFF
Greater than 10	seconds	= ALL OFF

SEQUENCED RELAY CONTROL

DIP Switch 3 "OFF" (DIP Switch 4 N/A). One through Four relays may be turned "ON" sequentially. A single pulse width modulated signal will bring on one or multiple relays in sequencing order. A stage-up process will occur starting with a 30 second delay before RELAY 1 activates. Following this, there will be a 60 second delay between the activation of RELAY 2, likewise for

relays 3 and 4. After the last commanded relay has been energized, the DMUX no longer utilizes the staging procedure. The relays will update immediately (higher or lower) with any subsequent change in the input signal and continue in that manner until the relays are commanded to ALL OFF, or a power failure occurs. The stage up procedure will start again with the completion of the next pulse command. If power was lost and then re-applied to the DMUX, the the next signal will cause the sequencing procedure to take place again to activate the appropriate relays.

Pulses falling anywhere within the same timing window will have the same relay output value. Input signals in excess of 10 seconds will result in ALL OFF with the DMUX ignoring the rest of the signal or if no signal is detected for 10 seconds, the relay output will fail to ALL OFF.

<u>PULSE LENGTH IN SECONDS</u>		<u>RELAY ACTION</u>
<u>Less than or equal to</u>	<u>Less than</u>	
.001	to .40	= NONE
.40	to .83	= ALL OFF
1.10	to 1.36	= 1 ON, Others OFF
1.63	to 1.89	= 1,2 ON, Others OFF
2.16	to 2.42	= 1,2,3 ON, Others OFF
2.69	to 10.00	= ALL ON.
Greater than 10 seconds		= ALL OFF

SIGNAL CONNECTION

- 1) Jumper J10 selects either standard (digital or dry contact) or triac type signal input. **Select Triac.** See Figures F, G, H or I on page 1 for signal input wiring, and Figure E for triac input jumper setting. Do not apply greater than 24 VAC @ 2 amps to relay contact circuits.

INSTALLATION AND CHECKOUT



AC OR DC JUMPER SETTING AND POWER CONNECTIONS:

- 1) 24 VDC -Before connecting power, place J9 shunt in DC position (see Fig. D, page 1) and connect power supply (see Fig. F, G, H or I) to “+” and “-” power terminals.
24 VAC -Before connecting power, place J9 shunt in AC position (see Fig. D, page 1), connect one transformer secondary leg (see Fig. F, G, H or I) to the “+” power terminal and the other to the “-” power terminal.
Any field device connected to this transformer must use the same common. If you are not sure of other field device configuration, use separate transformers.
- 2) If the 24 volt AC (or DC) power is shared with devices that have coils such as relays, solenoids, or other inductors, each coil must have an MOV, Transorb, (if DC, a diode or DC transorb with the cathode or banded side connected to the positive side of the power supply), or other spike snubbing device across each of the shared coils. Without these snubbers, coils produce very large voltage spikes when de-energizing that can cause malfunction or destruction of electronic circuits.
- 3) The secondary voltage should be isolated from earth ground, chassis ground, and neutral leg of the primary winding. Grounding should be to the system common only. If you do not follow these procedures improper operation can result.
- 4) You should measure the actual voltage output of the secondary. If the output is not fully loaded you may read a higher voltage than the circuit board can handle.

Apply power. The “POWER” LED should light. Close the pulse input relay contacts. The “PULSE” LED should light indicating that the DMUX is receiving the timing signal. Further test the DMUX operation by comparing the operation of output relays with respective input pulse. The LED for each relay will turn on when the respective relay is activated.

ACT TECH TIP

FOR PROPER OPERATION OF THE DMUX, ACT SUGGESTS LENGTHENING RAMPING TIMES ON THE NOVAR CONTROLLER...

Successful DMUX applications with Novar controllers have been done with programs having sensor response time changed to 2.5 minutes, and actuator ramping time greater than or equal to 250 seconds.

Contact ACT Factory Technical Support at 800-886-2281 if you have any questions.

Power Supply:	24 VAC or 24 VDC +/- 10%
Power Consumption:	130mA

Hysteresis:	130 milliseconds
Contact Rating:	2 amps @ 24 volts