

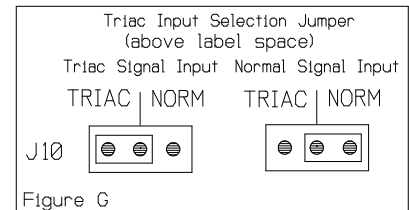

## Pulse Width Modulated Input to Four or Eight Addressable Relay Outputs

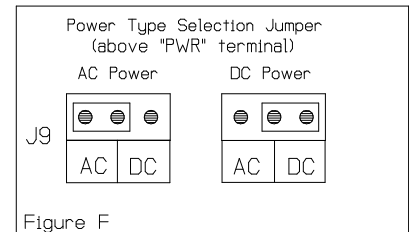
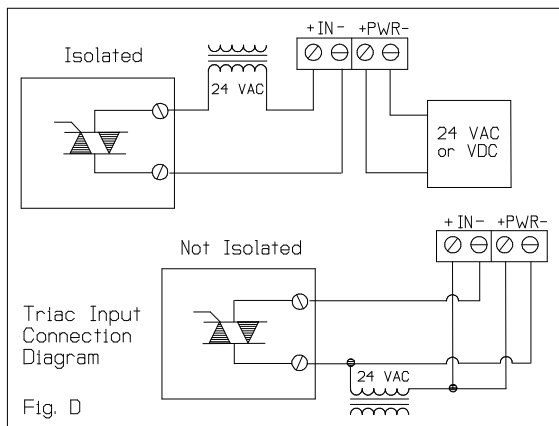
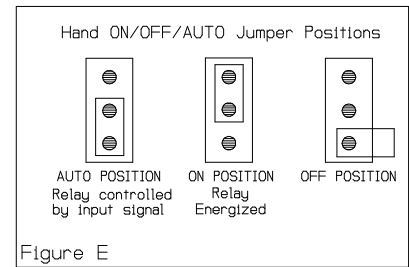
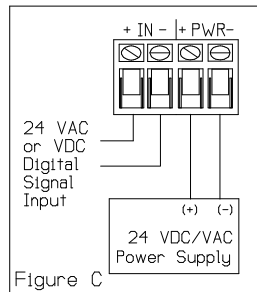
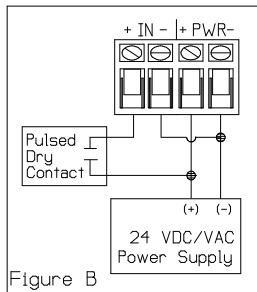
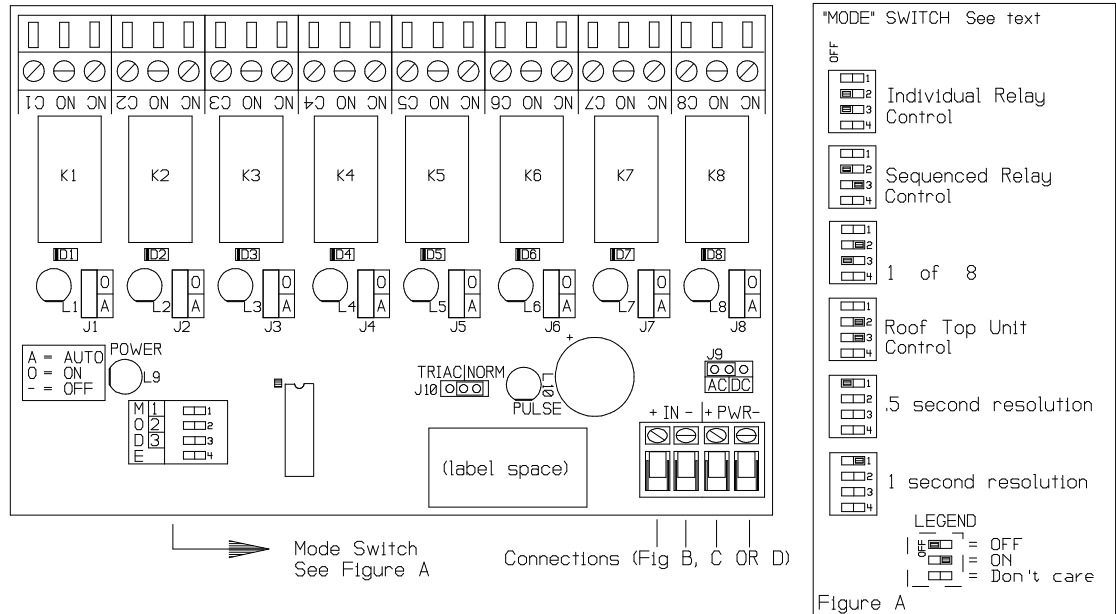

### INSTALLATION

#### READ THESE INSTRUCTIONS BEFORE YOU BEGIN INSTALLATION.

Ground yourself before touching board. Some components are static sensitive.

#### MOUNTING:

Circuit board may be mounted in any position. If circuit board slides out of snap track, a non-conductive "stop" may be required.

Use only fingers to remove board from snap track. Slide out of snap track or push against side of snap track and lift that side of the circuit board to remove. Do not flex board. Use no tools.

**POWER CONNECTIONS AND POWER TYPE JUMPER SETTING:**

- 1) 24 VDC -Before connecting power, place J9 shunt in DC position (see Fig. F, page 1) and connect power supply (see Fig. B, C, or D) to “+” and “-” power terminals.  
 24 VAC -Before connecting power, place J9 shunt in AC position (see Fig. F, page 1), connect one transformer secondary leg (see Fig. B , C or D) to the “+” power terminal and the other to the “-” power terminal.  
 Any field device connected to this transformer must use the same common. If you are not sure of other field device configuration, use separate transformers.
- 2) If the 24 volt AC (or DC) power is shared with devices that have coils such as relays, solenoids, or other inductors, each coil must have an MOV, Transorb, (if DC, a diode or DC transorb with the cathode or banded side connected to the positive side of the power supply), or other spike snubbing device across each of the shared coils. Without these snubbers, coils produce very large voltage spikes when de-energizing that can cause malfunction or destruction of electronic circuits.
- 3) The secondary voltage should be 24 volts (+/- 10%) and isolated from earth ground, chassis ground, and neutral leg of the primary winding. Grounding should be to the system common only. If you do not follow these procedures improper operation can result.
- 4) You should measure the actual voltage output of the secondary. If the output is not fully loaded you may read a higher voltage than the circuit board can handle.

**SIGNAL CONNECTION AND SIGNAL TYPE JUMPER SETTING**

- 1) Jumper J10 selects either standard (digital or dry contact) or triac type signal input. See Figure B, C or D on page 1 for signal input wiring, and Figure G for triac input jumper setting. Do not apply greater than 24 vac @ 2 amps to relay contact circuits.

**CHECKOUT**

Apply power: the “POWER” LED should light. Close the pulse input relay contacts: the “PULSE” LED should light indicating that the DMUX is receiving the timing signal. Further test the DMUX operation by comparing the operation of output relays with respective input pulse. The LED for each relay will turn on when the respective relay is activated.

**DIP SWITCH SELECTABLE CONTROL MODES:** Individual Relay Control, Sequenced Relay Control, Selected 1 (only) of 8 Relay Control, and Roof Top Unit Control (See Fig. A, page 1)

**RESOLUTION SWITCH:** Changes the pulse resolution on all modes (See Fig. A, page 1)

**SEQUENCED RELAY CONTROL** - This mode allows a single pulse to bring on multiple relays in sequencing order.

SWITCH SETTING: 2 OFF, 3 ON, 1 OFF for .5 second resolution, or 1 ON for 1 second resolution

| PULSE LENGTH IN SECONDS |                  | RELAY ACTION                 |
|-------------------------|------------------|------------------------------|
| (.5s)Resolution         | ( 1s )Resolution |                              |
| .5                      | 1                | ALL OFF                      |
| 1                       | 2                | 1 ON, Others OFF             |
| 1.5                     | 3                | 1,2 ON, Others OFF           |
| 2                       | 4                | 1,2,3 ON, Others OFF         |
| 2.5                     | 5                | 1,2,3,4 ON, Others OFF       |
| 3                       | 6                | 1,2,3,4,5 ON, Others OFF     |
| 3.5                     | 7                | 1,2,3,4,5,6 ON, Others OFF   |
| 4                       | 8                | 1,2,3,4,5,6,7 ON, Others OFF |
| 4.5                     | 9                | 1,2,3,4,5,6,7,8 ON.          |

No action on longer pulses.

**INDIVIDUAL RELAY CONTROL** - This mode allows the relays to be controlled individually as well as ALL ON and ALL OFF commands. All relays are OFF when power is applied. Each relay will hold its last commanded position until power loss.

Switch setting: 2 and 3 OFF, 1 OFF for .5 second resolution, or 1 ON for 1 second resolution

| PULSE LENGTH IN SECONDS |                | RELAY ACTION |
|-------------------------|----------------|--------------|
| (.5s)Resolution         | (1s)Resolution |              |
| .5                      | 1              | ALL OFF      |
| 1                       | 2              | 1 OFF        |
| 1.5                     | 3              | 1 ON         |
| 2                       | 4              | 2 OFF        |
| 2.5                     | 5              | 2 ON         |
| 3                       | 6              | 3 OFF        |
| 3.5                     | 7              | 3 ON         |
| 4                       | 8              | 4 OFF        |
| 4.5                     | 9              | 4 ON         |
| 5                       | 10             | 5 OFF        |
| 5.5                     | 11             | 5 ON         |
| 6                       | 12             | 6 OFF        |
| 6.5                     | 13             | 6 ON         |
| 7                       | 14             | 7 OFF        |
| 7.5                     | 15             | 7 ON         |
| 8                       | 16             | 8 OFF        |
| 8.5                     | 17             | 8 ON         |
| 9                       | 18             | ALL ON       |

No action on longer pulses.

**ONE OF EIGHT** - This mode allows only one relay at a time to be on. This mode is useful as an analog or digital signal multiplexer.

SWITCH SETTINGS: 2 ON, 3 OFF, 1 OFF for .5 second resolution, or 1 ON for 1 second resolution

| PULSE LENGTH IN SECONDS |                | RELAY ACTION    |
|-------------------------|----------------|-----------------|
| (.5s)Resolution         | (1s)Resolution |                 |
| .5                      | 1              | ALL OFF         |
| 1                       | 2              | 1 ON Others OFF |
| 1.5                     | 3              | 2 ON Others OFF |
| 2                       | 4              | 3 ON Others OFF |
| 2.5                     | 5              | 4 ON Others OFF |
| 3                       | 6              | 5 ON Others OFF |
| 3.5                     | 7              | 6 ON Others OFF |
| 4                       | 8              | 7 ON Others OFF |
| 4.5                     | 9              | 8 ON Others OFF |
| 5                       | 10             | ALL OFF         |

No action on longer pulses.

**ROOF TOP UNIT CONTROL** - This mode allows a single pulse to bring on relay combinations that are useful in controlling Roof Top Units.

SWITCH SETTINGS: 2 ON, 3 ON, 1 OFF for .5 second resolution, or 1 ON for 1 second resolution

**EXAMPLE:**

| Relay number | RTU Control Function (Examples only) |
|--------------|--------------------------------------|
| 1            | Fan                                  |
| 2            | Cool1                                |
| 3            | Cool2                                |
| 4            | Heat1                                |
| 5            | Heat2                                |
| 6            | Heat3                                |
| 7            | Heat4                                |
| 8            | Economizer                           |

| PULSE LENGTH IN SECONDS |                | RELAY ACTION (Examples only)      |
|-------------------------|----------------|-----------------------------------|
| (.5s)Resolution         | (1s)Resolution |                                   |
| .5                      | 1              | ALL OFF                           |
| 1                       | 2              | Fan only ( turns off Economizer ) |
| 1.5                     | 3              | Fan, Cool1                        |
| 2                       | 4              | Fan, Cool1, Cool2                 |
| 2.5                     | 5              | Fan, Heat1                        |
| 3                       | 6              | Fan, Heat1, Heat2                 |
| 3.5                     | 7              | Fan, Heat1, Heat2, Heat3          |
| 4                       | 8              | Fan, Heat1, Heat2, Heat3, Heat4   |
| 4.5                     | 9              | Fan, Economizer                   |

**Note:** The 4 relay version will go to 2.5 seconds (.5s resolution) or 5 seconds (1s resolution) in controlling the 4 relays.

Custom versions of the DMUX are available that include Pulse Addressing (the ability to address one of several DMUX boards, and then control its relays), different pulse time resolutions and relay output combinations. Please contact the sales department with your requirements.

|                         |  |
|-------------------------|--|
| Supply Voltage          | 24 VAC or 24 VDC, +/- 10%  |
| Supply Current          | 200 mA maximum, 25 mA per relay  |
| Input Pulse Source      | Relay, transistor or triac (jumper selectable).                              |
| Pulse Trigger Level     | 5 to 24 volts AC or DC, 20 mA maximum  |
| Off Time Between Pulses | 10 milliseconds minimum  |
| Pulse Resolution        | .5 seconds or 1 second, DIP switch selectable (custom PWM inputs available). |