

## Solidyne™ Slow Pulse Input to Proportional Resistance Output

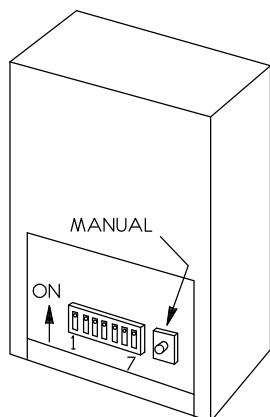

### INPUT SIGNAL



### SLOW PULSE SWITCH SETTINGS

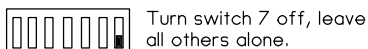

### MANUAL OVERRIDE

**Use caution when replacing cover on DRN4. Excess pressure could change switch setting when you slide it closed.**

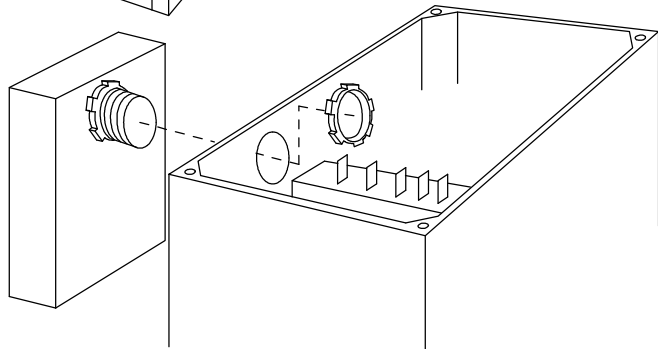

### WIRE TERMINATION ASSEMBLY GUIDE

COLOR	CONNECTION	Wire Termination is
White	Motor W (min)	Female Spade
Blue	Motor B (max)	Female Spade
Red	Motor R (wiper)	Female Spade
Black	Motor T2	Female Spade
Orange	Motor T1	Female Spade
Black	24 VAC (-)	Male Spade
Orange	24 VAC (+)	Male Spade
Yellow	Pulse Input Signal	Flying Lead
Green	Signal Common	Flying Lead
Gray	(not used) cap with wire nut	

### WIRING DIAGRAM

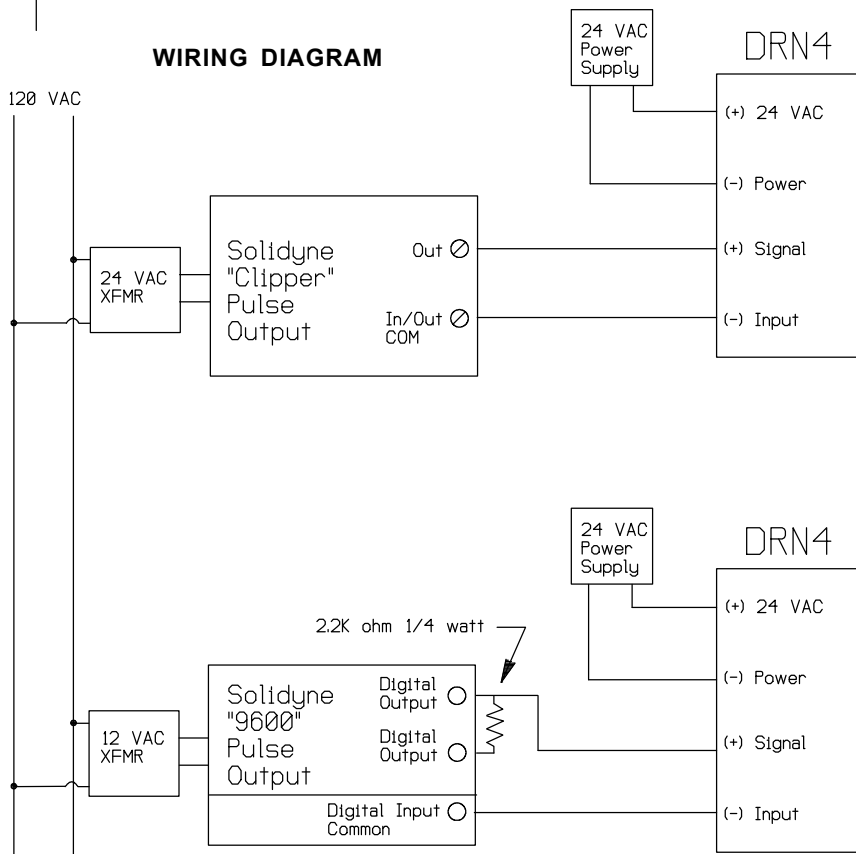

## INSTALLATION

---

### READ THESE INSTRUCTIONS BEFORE YOU BEGIN INSTALLATION

General tools that may be required are a Phillips screwdriver for the actuator cover, wire nuts for connections and a voltmeter for troubleshooting if necessary.

Turn off power to the actuator and remove the actuator cover. Remove a knock-out that is near the actuator control terminals. Open the switch access cover on the DRN4 and set the switches to the Solidyne™ pulse range. Replace the switch access cover on the DRN4 and remove the outermost lock-nut from the DRN4 box connector fitting. Feed the DRN4 wires through the actuator knock-out and lock-nut. Tighten the lock-nut onto the DRN4 fitting. Connect the DRN4 leads to the correct actuator terminals, the external control and the power source. Wire nut any unused wire and replace the actuator cover.

### POWER CONNECTIONS

Be sure to follow all local and electrical codes. Refer to wiring diagram for connection information.

- 1) The secondary supply voltage to the interface should be isolated from earth ground, chassis ground, and neutral leg of the primary winding. Any field device connected to this transformer must use the same common. If you are not sure of other field device configuration, use separate transformers.
- 2) If the 24 volt AC power is shared with other devices that have coils such as relays, solenoids, or other inductors, each coil must have an MOV, Transorb, or other spike snubbing device across each of the shared coils. Without these snubbers, coils produce very large voltage spikes when de-energizing that can cause malfunction or destruction of electronic circuits.

## CHECKOUT

---

### NOTE: Turn OFF Power Before Installation!

We recommend wiring into DRN4 pulse input terminals with 22AWG twisted pair or shielded cable, for added protection. Program the Solidyne Clipper controller load polarity for "Energized=ON" mode of operation. The Solidyne 9600 controller needs a 2.2K $\Omega$  1/4 watt resistor (included), between the digital output (+) and (-), which will be connected to the (+) input wire of the DRN4. The digital input common is connected to the (-) input wire of the DRN4. Program the Solidyne 9600 controller load polarity for "Energized=OFF" mode of operation. Program the Solidyne Controllers for a slow pulse input range of 4-96%. Select Dip switch mode for the SLOW PULSE range as shown in the diagram on page one. Switches 2, 4, 5, 6 & 7 should be ON (or up).

Turn on power to the actuator and have the external controller send a minimum signal and then a maximum command signal to verify proper actuator positioning.

### MANUAL OPERATION WITH OVERRIDE BUTTON:

Manual operation is possible by placing dip switch 7 in the "OFF" position. This will permit manipulation of the output using the manual override button. Be sure to return switch 7 to the "ON" position after checkout.

### MANUAL PULSE SIGNAL INPUT

Pressing override button allows you to manually simulate a pulse within the range selected by the DIP switches. Given the SLOW PULSE range, holding the override button for approximately 3 seconds moves the actuator approximately 50%.

Power Consumption:	130 mA	Output: 0-135 ohms
Input Impedance:	Voltage/100,000 ohms Current/250 ohms	Output Resolution: 32 steps